



# GREEN ENERGY NETWORK

Regd. Office: -H.No.1534/C-101 Parmar Nagar Co.Op.Hsg.Soc. At Bhuvaneshwar,  
Post Varse, Tal.Roha-Raigad Maharashtra 402109 India. 8308378882/9422094430



**TDS**

## FLAME PROOF LED COB WELL GLASS ( ECO SUPER ) - 45 W



### Product Specification

Name	45 W Led Flame Proof Well Glass
Model No	FLPWGCOB-ES-45
Doc.No	FLPWGCOB-ES-45/1
Date	02/02/2021.

### Application

Chemical Industries	Oil Refinery
Mining Industries	Hazardous Industries
Petro Chemical Industries	Pharma Industries

### Technical Specification of Energy Efficient 15 W Led COB Flame Proof Well Glass ( Eco Super )

Characteristics	Standred Value
Luminaries Wattage	45 Watt ( ± 5% )
Luminaries Input Voltage	240 Voltage
Luminaries Input Frequency	50 Hz
Luminaries Input Current	0.3 A.
Luminaries Power Factor & THD	>0.96 THD <10%
Luminaries Efficiency	86%
Luminaries Light Spreading Angle	Diffuser Lens
Luminaries Temperture Class	T 6
Luminaries IP Standred	Indoor IP 66
Luminaries Total Weight	6.0 Kg ( Approx )
Luminaries Starting Time	Rapid .4 Sec.
Luminaries Warranty	3 Years
LED Make	Citizen / Bridgelux
LED Certification	LM 80
LED Lamp Type	COB
LED Lamp Lumen @25 Degree C	5961
LED Lamp Lumen Efficacy (Lm/Watt)	160 - 165 lm / W
LED Lamp CCT/ Color Rendering Index	6500K / RA 80 Min
LED Lamp Wattage/ Current / Voltage	41.4 W / 1150 mA / 30 - 39 V @ Tc 25 Degree C.
LED Lamp Life	50,000 Hours
LED Lamp Identification Feature	TDS
Actual test report of LED Lamp	Actual Operating test Report for 50,000 Hrs.
Driver Type	Constant Current ( CC ) Mode ( Eco Led / Fulham )
Driver Input Voltage Range	90 ~ 305 V AC
Driver Frequency Range	47 Hz - 63 Hz
Driver Output Protection	Short Circuit, Over Voltage, Low Voltage & Surge
Driver Surge Protection	4 KV Inbuilt
Luminaries Juction Temperature - Tj	< 78° C.
Luminaries Case Temperature - Tc	< 65° C.
MOC- Heat sink	Aluminium Casting - LM -06

**Certification : CIMFR & PESO Approved**

**Enclosure Make : ILS / Sudhir / Agnus**



Regd.Office:-H.No.1534/C-101 Parmar Nagar Co.Op.Hsg.Soc. At Bhuvaneshwar,  
Post Varse,Tal.Roha-Raigad Maharashtra 402109 India. 8308378882/9422094430

## Schematic Drawing

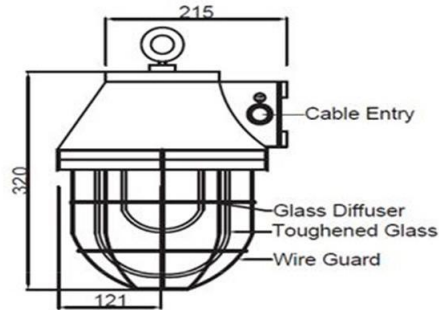

- All Technical Parameterrs & Drawing consider + - 05%

### SPECIALITY :

This Fixure is providing required spreaded illumination level without Glare through diffused light. Products are having Precise Thermal management for longer life and Precise light spreading angle for required illumination.

- Information & Product Change With Out Any Notice

Prepared By

Reviewed By

Approved By

### SALES & MARKETING OFFICE

SHOP NO.03 & 04, SUNCITY GARDEN PHASE NO.01, BEHIND NAVRATNA HOTEL, AT BHUVANESHWAR, POST- VARSE TAL.  
ROHA, DIST-RAIGAD, MAHARASHTRA 402109 INDIA. PH.NO.02194-233900, 8308378882, 8308378252  
Email: [sales@genlights.in](mailto:sales@genlights.in), Web: [www.genlights.in](http://www.genlights.in)

### FACTORY I

686, AT POST MEDHA, HANUMANT ALI, NEAR BHAI RI TEMPLE, TAL- ROHA, DIST-RAIGAD, MAHARASHTRA 402109 INDIA.

### FACTORY II

SHED NO.9/10/11, SURVEY NO.298/1, NEAR L-230, NAGAPUR MIDC, AHMEDNAGAR 414111

